

OPERATING & MAINTENANCE MANUAL

Extend Surface Area Type H/Ex. for Compressor

DYNAMIC & SPECIAL COMPANY

DASCO

www.dascohex.com

CONTENTS



1. INTRODUCTION

- 1.1 INTRODUCTION OF H/EX
- 1.2 DESIGN & MANUFACTURE APPLICATION CAPACITY
- 1.3 FIN/TUBE MATERIAL COMBINATIONS

2. STORAGE & LIFTING

- 2.1 RUST PREVENTION for INTERNAL (for VCI)
- 2.2 RUST PREVENTION for INTERNAL (for DRY AIR or N2 CHARGE)
- 2.3 RUST PREVENTION for OUTSIDE
- 2.4 LIFTING

3. SITE OR SHOP INSTALLATION

4. OPERATION

- 4.1 START-UP OPERATION
- 4.2 SHUT-DOWN OPERATION

5. MAINTENANCE

- 5.1 CHEMICAL CLEANING
- 5.2 PHYSICAL CLEANING
- 5.3 PRECAUTIONS FOR RE-ASSEMBLY
- 5.4 CORRECTIVE ACTION FOR TUBE DAMAGE

APPENDIX-1 SPECIFICATION OF SILICAGEL

APPENDIX-2 INSTALLATION PROCEDURE (As per TEMA Code)

APPENDIX-3 OPERATION PROCEDURE (As per TEMA Code)

APPENDIX-4 MAINTENANCE PROCEDURE (As per TEMA Code)

APPENDIX-5 TORQUE VALUE TABLE (DASCO'S STD)

*** HOW TO CONTACT US**

1. INTRODUCTION

1.1 INTRODUCTION OF H/EX.

* Flow Diagram

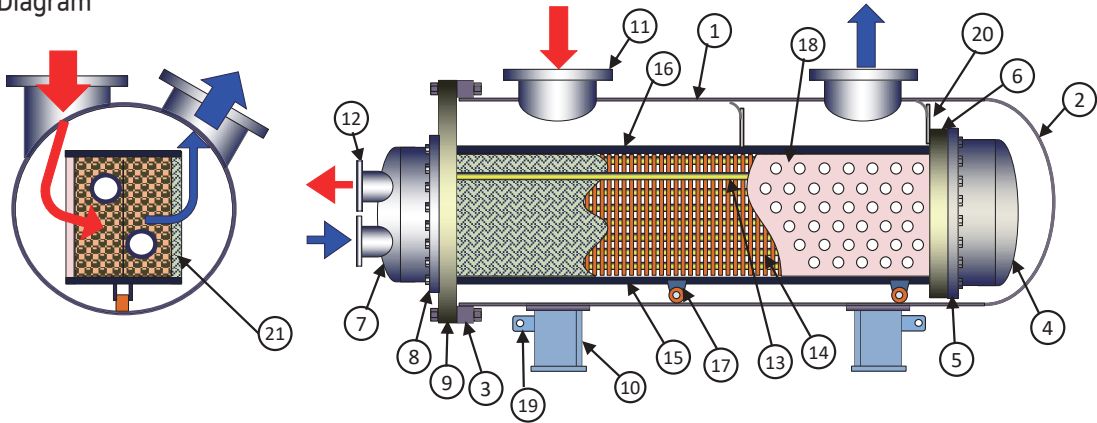

* Nomenclature of Heat Exchanger Components

1. Shell	8. Channel Flange	15. Lower Guide Plate w/Gas Seal plate
2. Shell - Head or End Plate or Flange Cover	9. Front Tubesheet	16. Upper Guide Plate w/Seal plate
3. Shell - Flange or End Plate	10. Saddle	17. Roller Ass'y
4. Reversing Cover - Head or End Plate	11. Shell Nozzle (In/Outlet)	18. Punching Plate
5. Reversing Cover Flange or Reversing	12. Channel Nozzle (In/Outlet)	19. Earth Lug
6. Rear Tubesheet	13. Tube	20. Back Divide Plate w/Gas Seal plate
7. Channel - Head or End Plate or Flange Cover	14. Plate Fin	21. Demister

1.2 DESIGN & MANUFACTURE APPLICATION CAPACITY

a) Inside diameters : 450mm ~ 3,000mm b) Tube effective length : Max. 12,000mm

1.3 FIN/TUBE MATERIAL COMBINATIONS

1.3.1 PLATE FIN TYPE

TUBE MATERIAL	FIN MATERIAL
SA213-TP304(L), 316(L) or Eq'	ALUMININUM (+COATING) (0.25 mm or 0.15 mm)
SA789-S31803 or Eq'	
SB75-C12200 (O50) or Eq'	COPPER (+COATING) (0.25 mm or 0.15 mm)
SB111-C44300 (O61) or Eq'	
SB111-C70600 (O61) or Eq'	STAINLESS STEEL (+COATING) (0.15 mm)
SB111-C71500 (O61) or Eq'	

1.3.1.1 DASCO STANDARD MOLD FOR PLATE FIN

*T.P : Transverse Pitch (Step Pitch)
*L.P : Longitudinal Pitch (Row Pitch)

NO.	TUBE O.D	L.P	T.P	Fin Pitch
1	19.05	33	38.1	2.0 ~ 3.6
2	15.88 (or 16)	27.7	32	1.6 ~ 3.0
3	15.88 (or 16)	25.4	38.1	1.5 ~ 4.5
4	15.88 (or 16)	33	38.1	2.0 ~ 3.6
5	15.88 (or 16)	43.3	50	6.0 ~ 13.0
6	12	17	24	1.3 ~ 1.6
7	9.52	21.65	25	1.6

1.3.1.2 TUBE TH'K FOR EXPANDING TO FIN

- a) COPPER MATERIAL : MAX. 2.77mm b) STAINLESS STEEL MATERIAL : MAX. 1.24mm

1.3.2 HIGH FIN TYPE

TUBE MATERIAL	FIN MATERIAL
ALL MATERIAL	ALUMINUM (+COATING)
	COPPER (+COATING)
	STAINLESS STEEL (+COATING)
	CARBON STEEL (+COATING)

1.3.3 BARE & LOW FIN TUBE TYPE

- ALL MATERIAL

2. STORAGE & LIFTING

2.1 RUST PREVENTION for INTERNAL (for VCI)

- a) Internal : shell & channel side [VCI-SILICAGEL (Refer to Appendix-1)]
- b) VCI Condition : 3 months storage at site.
- c) Re-fill the VCI every 3 months during storage

* Photo of Caution Mark



* Photo of VCI Filling



2.2 RUST PREVENTION for INTERNAL (for DRY AIR or N2 CHARGE)

- a) Internal : Shell & Tube side [Dry air or Nitrogen gas charge (0.3 barG ~ 0.5 barG)]
- b) Check the pressure gauge every 3 months during storage.
- c) Re-fill the Nitrogen gas if the pressure is decreased over 0.1 barG.

* Photo of N2 Charge



* Photo of P.G for N2 Charge



2.3 RUST PREVENTION for OUTSIDE

- a) Store under cover in a heated area (indoor) with dry, low humidity atmosphere.
- b) When storage outdoor, it's necessary to do extra packing to prevent entry of blowing dust, rain or snow, etc.

2.4 LIFTING

- a) Check the total weight of heat exchanger on name plate before lifting.
- b) Choose to lift by Crane or Fork-lift.

* Photo of Crane-lifting

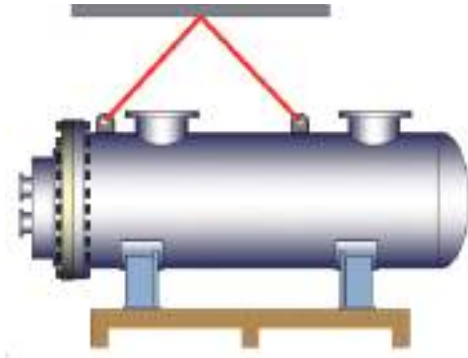

* Photo of Fork-lifting

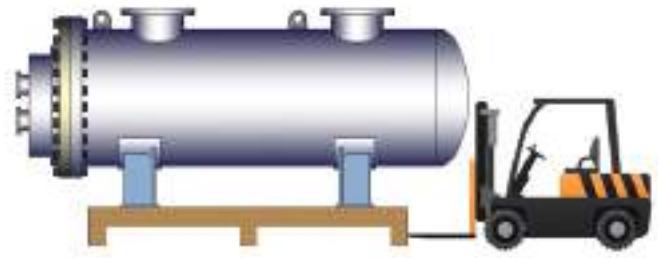

3. SITE OR SHOP INSTALLATION

- a) First, set the fixed side of saddle base plate, and set the sliding side of saddle base plate.

* Photo of saddle base plate

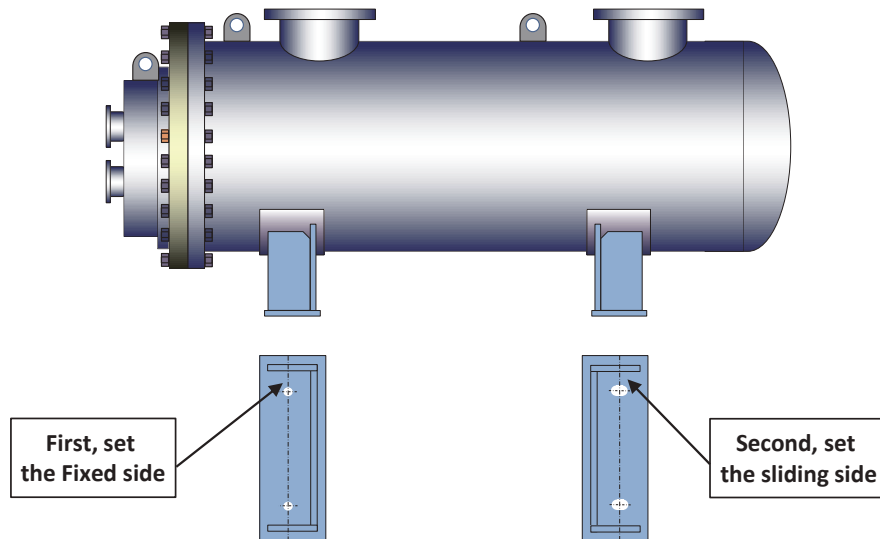

* Type of Anchor bolt

Type L

Type LA

Type J

Type JA

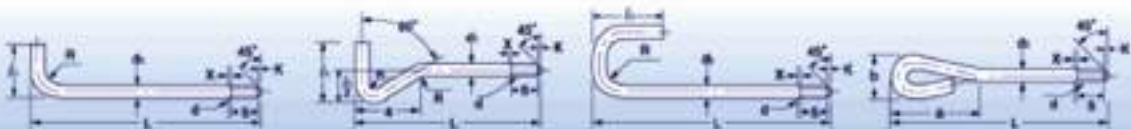

b) Connect gas side nozzle flange. Connecting method is shown as following.

* Photo of Flange Joint type



Slip-On



Welding Neck



Lapped

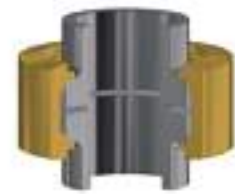

V-Joint

* Photo of Flange facing



Raised Face



Flat Face



Ring type Joint

c) Connect cold fluid(water) side nozzle flange.

4. OPERATAION

4.1 START-UP OPERATION

- Open vent valve on cold fluid side, and flow the cold fluid to heat exchanger.
- After flowing up, close the vent valve after discharging air.
- After closing the vent valve, increase the pressure slowly not over than 5 barG per min.
- After flowing up the hot fluid, increase the pressure slowly not over than 5 barG per min.
- Check any leak on all connections.

4.2 SHUT-DOWN OPERATION

- First, shut down the hot fluid line.
- Next, shut down the cold fluid line.

5. MAINTENANCE

5.1 CHEMICAL CLEANING

- a) Select proper chemicals considering site condition, and remove the foreign materials.
** Proper chemicals shall be selected after discussing it with specialized company.*
- b) After that rinse inside with pressured clean water.

5.2 PHYSICAL CLEANING

5.2.1 SHELL SIDE CLEANING

- a) Bundle removal is proceeded as following procedure.
 - 1) Loosen the tubesheet with channel flange using the Jack bolts.
 And then dis-assemble channel to tubesheet.

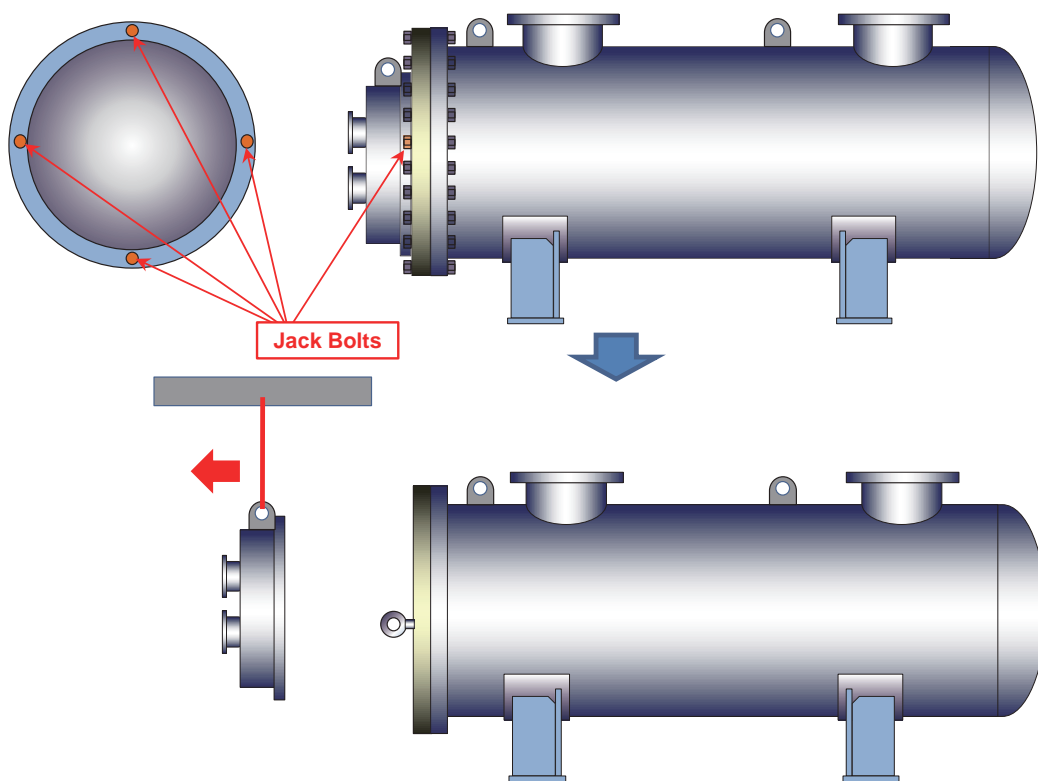

- 2) Pull the tube bundle using the eyebolt on front tubesheet to first lifting lug.

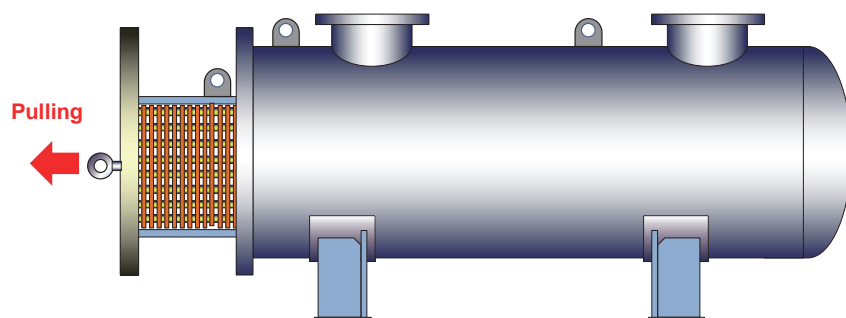

3) Connect crane to first lifting lug. And then pull the tube bundle.

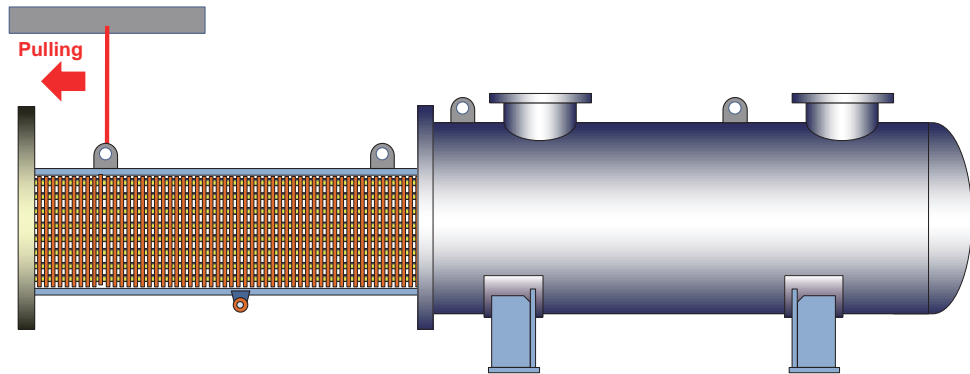

4) Pull the tube bundle to second lifting lug, and connect the other crane to second lifting lug.

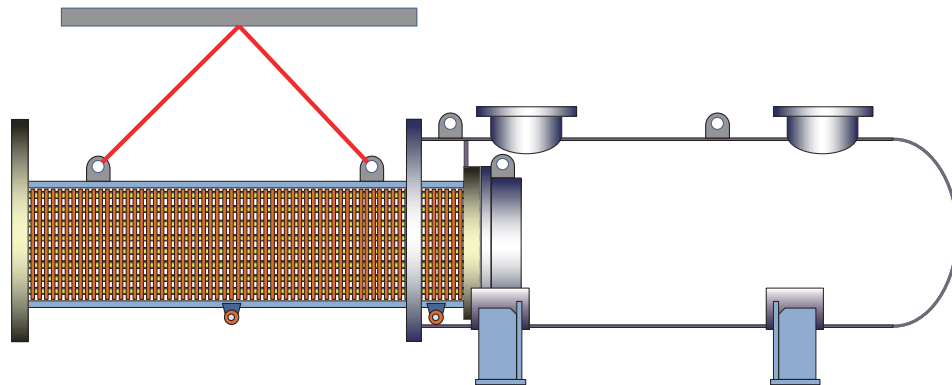

5) Set the tube bundle on the wooden skid to clean.

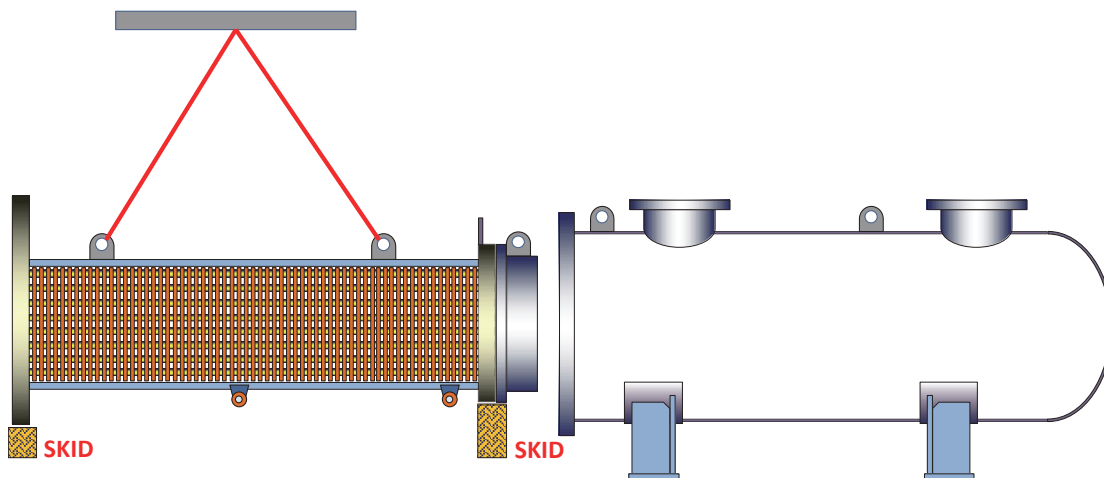

b) Clean the shell side with pressured clean water.

5.2.2 TUBE SIDE CLEANING

a) Rear cover removal is proceeded as following procedure.

1) Connect the crane to lifting lug on rear cover.

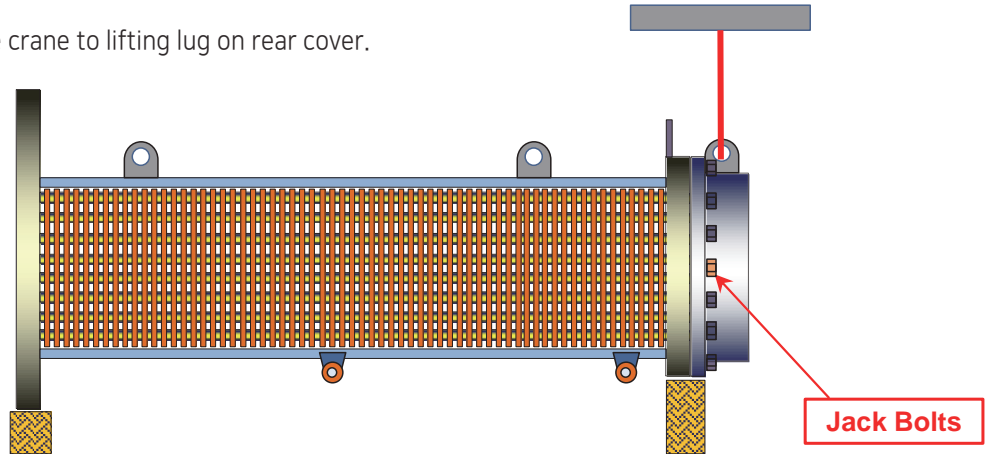

2) Dis-assemble the covers loosening Jack bolts, set them on the wooden skid.

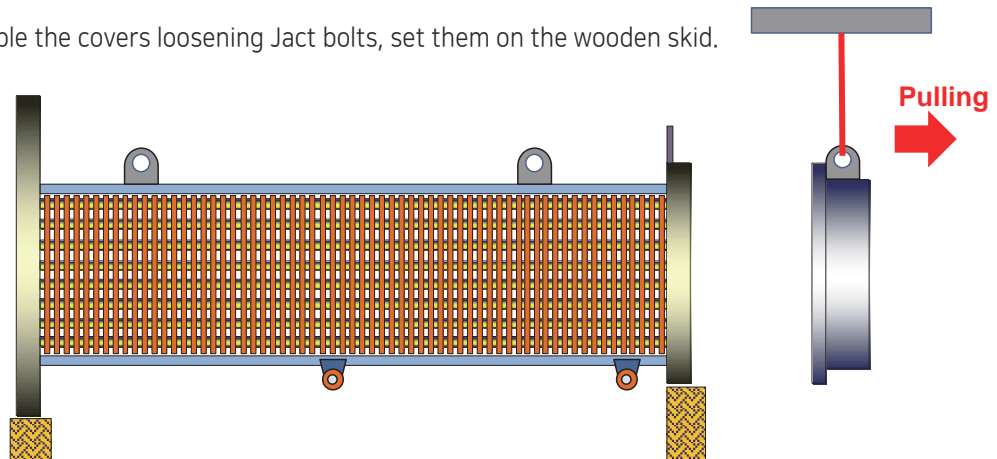

b) Clean the inside of front cover and rear cover with pressured clean water.

c) Clean the tube inside with wire brush.

Tube O.D	Brush O.D
Φ19.05	Φ22
Φ16 (Φ15.88)	Φ18
Φ12	Φ14
Φ9	Φ12

* Photo of Tube Cleaning by Bursh

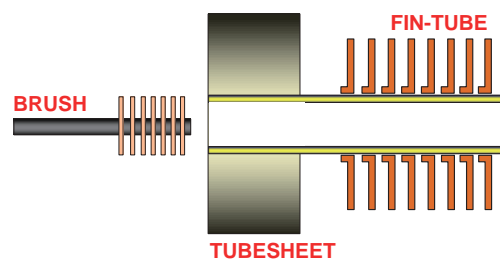

5.3 PRECAUTIONS FOR RE-ASSEMBLY

- a) Replace gaskets as new one, and be careful in any damage on gasket surface.
- b) Replace air seal plate at all costs, and check the sealing between air seal plate and shell inside through shell side nozzles.
- b-1) When seal plate to be replaced, consider the direction of seal plate as following item.

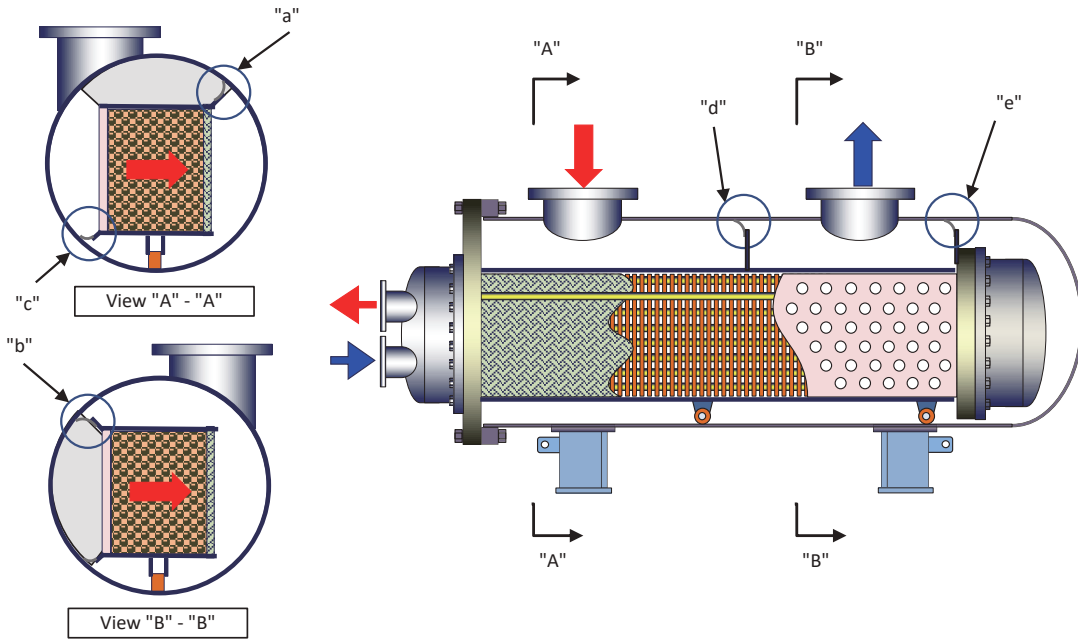

b-1.1) Upper Plate & Seal Plate (detail "a" & "b")

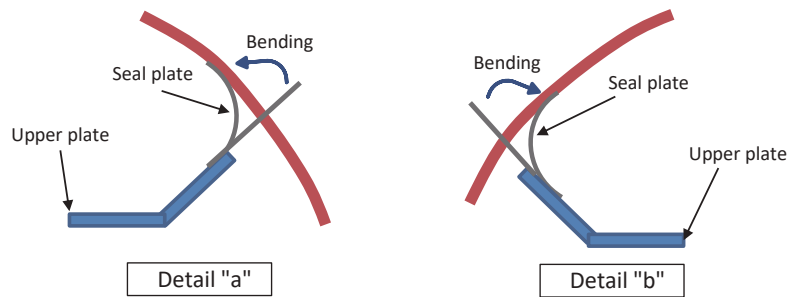

b-1.2) Lower Plate & Seal Plate (detail "c")

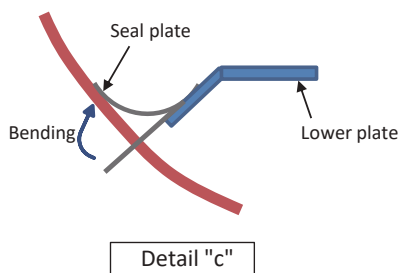

b-1.3) Middle Plate & Seal Plate (detail "d")

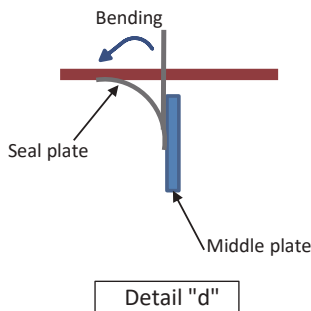

b-1.4) Rear Plate & Seal Plate (detail "e")

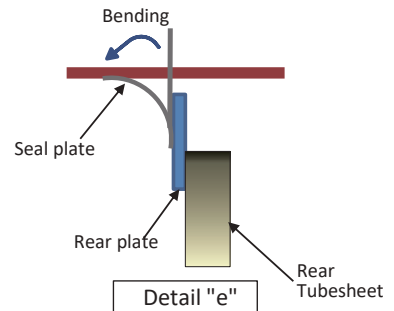

- b-2) Replacement shall be done to protect air bypass.
- b-3) If air bypass occurs by inappropriate assembling, there will be any problem on performance.
- c) If any damage is detected on the peak of bolt or nut, replace new one.
- d) At any cost, do the leak test.
- e) Any leak can happen by long terms storage, or screw loosening phenomenon due to hot fluid operation.
Then, re-fasten all bolts with nuts in accordance with Appendix-4.
- f) bolts/nuts shall be fastened with 40%, 80% and 100% of torque value per each size in accordance with Appendix-5.
- g) Touch-up the painting on any damage, and re-bolting area for rust prevention.

5.4 CORRECTIVE ACTION FOR TUBE DAMAGE

5.4.1 Plugging

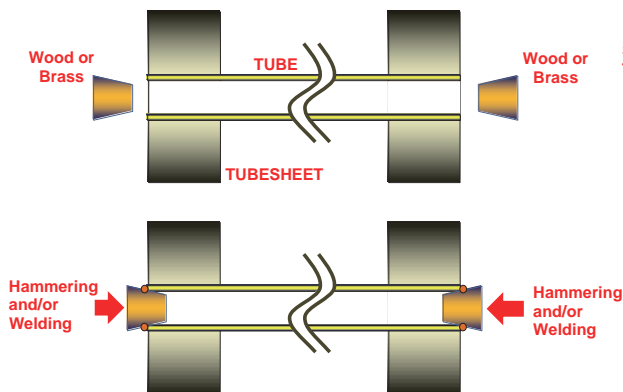

5.4.2 Double tubing

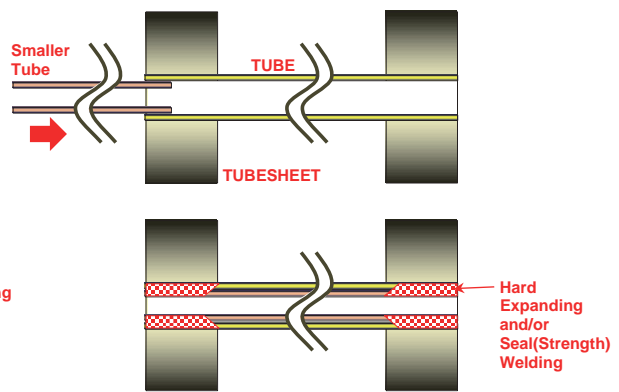

* PLUG SPEC.

Tube O.D	A x B x L
OD 12	8 x 12 x 40
OD 15.88 or 16	11 x 16 x 40
OD 19.05	14 x 19 x 40
OD 25.4	18 x 25 x 40

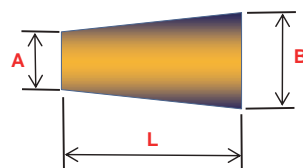

5.4.3 Tube replacement : Contact to Maker

APPENDIX-1

Alumina SilicaGel

Brief

Silica and Alumina composite Gel (AL2O3, SiO2)

Use

Dehydration of gases (petroleum-symmetry), Remove of oil mist in compressed gas or air, Filtration of liquid air, Remove of F or F, Catalyst.



Properties / Grade		Unit	SA	SB
Particle Size	4 MESH RESIDUE	%	20 Max	2.0 - 4.0
	4 - 8 MESH		80 Max	G or B
	8 MESH UNDER		0	-
Shape			Bead	
Moisture Content		%	2.0 Max	2.0 Min
Bulk Density		g/ml	0.720 - 0.780	0.630 - 0.690
Surface Area		m ² /g	500 Min	500 Min
True Specific Gravity		-	2.6	
2% Suspension PH		-	2.6	
Broken bead ratio		%	10 Max	10 Max
Pore Volume		ml/g	0.50	
Average Pore Diameter			50	
Broken Bead ratio in Water		%	2 Max	2 Max
Average Particle Strength		kg	10 Min	10 Min
Moisture Adsorption Capacity	5 %	RH %	5	
	20 %	RH %	12.5	
	50 %	RH %	27.7	
	75 %	RH %	33.5	
	90 %	RH %	34.9	
Remarks				

APPENDIX-2

E-2 INSTALLATION OF HEAT EXCHANGERS

E-2.1 HEAT EXCHANGER SETTINGS	
E-2.11 CLEARANCE FOR DISMANTLING	<p>For straight tube exchangers fitted with removable bundles, provide sufficient clearance at the stationary head end to permit removal of the bundle from the shell and provide adequate space beyond the rear head to permit removal of the shell cover and/or floating head cover.</p> <p>For fixed tubesheet exchangers, provide sufficient clearance at one end to permit withdrawal and replacement of the tubes, and enough space beyond the head at the opposite end to permit removal of the bonnet or channel cover.</p> <p>For U-tube heat exchangers, provide sufficient clearance at the stationary head end to permit withdrawal of the tube bundle, or at the opposite end to permit removal of the shell.</p>
E-2.12 FOUNDATIONS	<p>Foundations must be adequate so that exchangers will not settle and impose excessive strains on the exchanger. Foundation bolts should be set to allow for setting inaccuracies. In concrete footings, pipe sleeves at least one size larger than bolt diameter slipped over the bolts and cast in place are best for this purpose, as they allow the bolt center to be adjusted after the foundation has set.</p>
E-2.13 FOUNDATION BOLTS	<p>Foundation bolts should be loosened at one end of the unit to allow free expansion of shells. Slotted holes in supports are provided for this purpose.</p>
E-2.14 LEVELING	<p>Exchangers must be set level and square so that pipe connections may be made without forcing.</p>
E-2.2 CLEANLINESS PROVISIONS	
E-2.21 CONNECTION PROTECTORS	<p>All exchanger openings should be inspected for foreign material. Protective plugs and covers should not be removed until just prior to installation.</p>
E-2.22 DIRT REMOVAL	<p>The entire system should be clean before starting operation. Under some conditions, the use of strainers in the piping may be required.</p>
E-2.23 CLEANING FACILITIES	<p>Convenient means should be provided for cleaning the unit as suggested under "Maintenance of Heat Exchangers," Paragraph E-4.</p>
E-2.3 FITTINGS AND PIPING	
E-2.31 BY-PASS VALVES	<p>It may be desirable for purchaser to provide valves and by-passes in the piping system to permit inspection and repairs.</p>
E-2.32 TEST CONNECTIONS	<p>When not integral with the exchanger nozzles, thermometer well and pressure gage connections should be installed close to the exchanger in the inlet and outlet piping.</p>
E-2.33 VENTS	<p>Vent valves should be provided by purchaser so units can be purged to prevent vapor or gas binding. Special consideration must be given to discharge of hazardous or toxic fluids.</p>
E-2.34 DRAINS	<p>Drains may discharge to atmosphere, if permissible, or into a vessel at lower pressure. They should not be piped to a common closed manifold.</p>
E-2.35 PULSATION AND VIBRATION	<p>In all installations, care should be taken to eliminate or minimize transmission of fluid pulsations and mechanical vibrations to the heat exchangers.</p>
E-2.36 SAFETY RELIEF DEVICES	<p>The ASME Code defines the requirements for safety relief devices. When specified by the purchaser, the manufacturer will provide the necessary connections for the safety relief devices. The size and type of the required connections will be specified by the purchaser. The purchaser will provide and install the required relief devices.</p>

- As per TEMA 2019 10th ED SECTION 4, Installation, Operation, and Maintenance -

APPENDIX-3

E-3 OPERATION OF HEAT EXCHANGERS

E-3.1 DESIGN AND OPERATING CONDITIONS	<p>Equipment must not be operated at conditions which exceed those specified on the name plate(s).</p>
E-3.2 OPERATING PROCEDURES	<p>Before placing any exchanger in operation, reference should be made to the exchanger drawings, specification sheet(s) and name plate(s) for any special instructions. Local safety and health regulations must be considered. Improper start-up or shut-down sequences, particularly of fixed tubesheet units, may cause leaking of tube-to-tubesheet and/or bolted flanged joints.</p>
E-3.21 START-UP OPERATION	<p>Most exchangers with removable tube bundles may be placed in service by first establishing circulation of the cold medium, followed by the gradual introduction of the hot medium. During start-up all vent valves should be opened and left open until all passages have been purged of air and are completely filled with fluid. For fixed tubesheet exchangers, fluids must be introduced in a manner to minimize differential expansion between the shell and tubes.</p>
E-3.22 SHUT-DOWN OPERATION	<p>For exchangers with removable bundles, the units may be shut down by first gradually stopping the flow of the hot medium and then stopping the flow of the cold medium. If it is necessary to stop the flow of cold medium, the circulation of hot medium through the exchanger should also be stopped. For fixed tubesheet exchangers, the unit must be shut down in a manner to minimize differential expansion between shell and tubes. When shutting down the system, all units should be drained completely when there is the possibility of freezing or corrosion damage. To guard against water hammer, condensate should be drained from steam heaters and similar apparatus during start-up or shut-down. To reduce water retention after drainage, the tube side of water cooled exchangers should be blown out with air.</p>
E-3.23 TEMPERATURE SHOCKS	<p>Exchangers normally should not be subjected abrupt temperature fluctuations. Hot fluid must not be suddenly introduced when the unit is cold, nor cold fluid suddenly introduced when the unit is hot.</p>
E-3.24 BOLTED JOINTS	<p>Heat exchangers are pressure tested before leaving the manufacturer's shop in accordance with ASME Code requirements. However, normal relaxing of the gasketed joints may occur in the interval between testing in the manufacturer's shop and installation at the jobsite. Therefore, all external bolted joints may require retightening after installation and, if necessary, after the exchanger has reached operating temperature.</p>
E-3.24.1	<p>It is possible for the bolt stress to decrease after initial tightening, because of slow creep or relaxation of the gasket, particularly in the case of the softer gasket materials.</p>

APPENDIX-3

E-3.24.2	Excessive initial bolt stress can cause yielding of the bolt itself. This is especially likely with bolts of small diameter or bolting having relatively low yield values such as stainless steels.
E-3.25 RECOMMENDED BOLT TIGHTENING PROCEDURE	
E-3.25.1	All gasket joint surfaces shall be clean and free of oil or debris. If the gasket requires assistance to be held in place for installation, grease shall not be used. Any tape applied to a spiral wound gasket for shipping or assembly shall be removed prior to installing the gasket. No tape, string or other object will be allowed to remain on the gasket surface once assembly is complete.
E-3.25.2	Thoroughly clean threads, nut faces and the flange where nut face bears. If roughness, burrs or any irregularity is present, dress it out to as smooth a surface as possible.
E-3.25.3	Thoroughly lubricate threads on studs, nuts and contacting surfaces on nuts and flange.
E-3.25.4	The joint shall be snugged up squarely so the entire flange face bears uniformly on the gasket.
E-3.25.5	<p>"Tightening of the bolts shall be applied in at least three equally spaced increments using a cross bolting pattern as illustrated in Figure E-3.25.5.</p>
E-3.25.6	Once the cross bolting patterns are complete; a circular chase pattern shall be applied until no nut rotation occurs.

FIGURE E-3.25.5

- As per TEMA 2019 10th ED SECTION 4, Installation, Operation, and Maintenance -

APPENDIX-4

E-4. MAINTENANCE OF HEAT EXCHANGERS

<p>E-4.1 INSPECTION OF UNIT</p>	<p>At regular intervals and as frequently as experience indicates, an examination should be made of the interior and exterior condition of the unit. Neglect in keeping all tubes clean may result in complete stoppage of flow through some tubes which could cause severe thermal strains, leaking tube joints, or structural damage to other components. Sacrificial anodes, when provided, should be inspected to determine whether they should be cleaned or replaced.</p>
<p>E-4.11 INDICATIONS OF FOULING</p>	<p>Exchangers subject to fouling or scaling should be cleaned periodically. A light sludge or scale coating on the tube greatly reduces its efficiency. A marked increase in pressure drop and/or reduction in performance usually indicates cleaning is necessary. The unit should first be checked for air or vapor binding to confirm that this is not the cause for the reduction in performance. Since the difficulty of cleaning increases rapidly as the scale thickness or deposit increases, the intervals between cleanings should not be excessive.</p>
<p>E-4.12 DISASSEMBLY FOR INSPECTION OR CLEANING</p>	<p>Before disassembly, the user must assure himself that the unit has been depressurized, vented and drained, neutralized and/or purged of hazardous material.</p> <p>To inspect the inside of the tubes and also make them accessible for cleaning, the following procedures should be used:</p> <ul style="list-style-type: none"> (1) Stationary Head End <ul style="list-style-type: none"> (a) Type A, C, D & N, remove cover only (b) Type B, remove bonnet (2) Rear Head End <ul style="list-style-type: none"> (a) Type L, N & P, remove cover only (b) Type M, remove bonnet (c) Type S & T, remove shell cover and floating head cover (d) Type W, remove channel cover or bonnet
<p>E-4.13 LOCATING TUBE LEAKS</p>	<p>The following procedures may be used to locate perforated or split tubes and leaking joints between tubes and tubesheets. In most cases, the entire front face of each tubesheet will be accessible for inspection. The point where water escapes indicates a defective tube or tube-to-tubesheet joint.</p> <ul style="list-style-type: none"> (1) Units with removable channel cover: Remove channel cover and apply hydraulic pressure in the shell. (2) Units with bonnet type head: For fixed tubesheet units where tubesheets are an integral part of the shell, remove bonnet and apply hydraulic pressure in the shell. For fixed tubesheet units where tubesheets are not an integral part of the shell and for units with removable bundles, remove bonnet, re-bolt tubesheet to shell or install test flange or gland, whichever is applicable, and apply hydraulic pressure in the shell. See Figure E-4.13-1 for typical test flange and test gland. <div style="text-align: center;"> </div>

APPENDIX-4

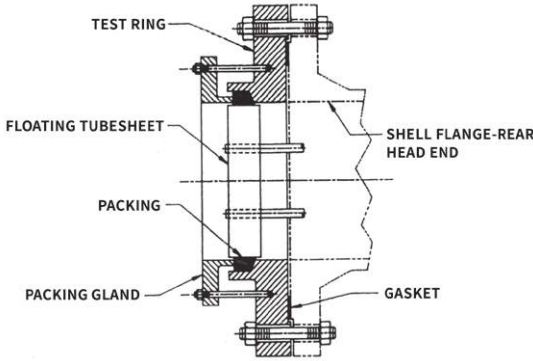
<p>E-4.13 LOCATING TUBE LEAKS</p>	<p>(3) Units with Type S or T floating head: Remove channel cover or bonnet, shell cover and floating head cover. Install test ring and bolt in place with gasket and packing. Apply hydraulic pressure in the shell. A typical test ring is shown in Figure E-4.13-2. When a test ring is not available it is possible to locate leaks in the floating head end by removing the shell cover and applying hydraulic pressure in the tubes. Leaking tube joints may then be located by sighting through the tube lanes. Care must be exercised when testing partially assembled exchangers to prevent over extension of expansion joints or overloading of tubes and/or tube-to-tubesheet joints.</p>  <p>(4) Hydrostatic test should be performed so that the temperature of the metal is over 60 F (16 C) unless the materials of construction have a lower nil-ductility transition temperature.</p>
<p>E-4.2 TUBE BUNDLE REMOVAL AND HANDLING</p>	<p>To avoid possible damage during removal of a tube bundle from a shell, a pulling device should be attached to eyebolts screwed into the tubesheet. If the tubesheet does not have tapped holes for eyebolts, steel rods or cables inserted through tubes and attached to bearing plates may be used. The bundle should be supported on the tube baffles, supports or tubesheets to prevent damage to the tubes.</p>
<p>E-4.3 CLEANING TUBE BUNDLES</p>	
<p>E-4.31 CLEANING METHODS</p>	<p>The heat transfer surfaces of heat exchangers should be kept reasonably clean to assure satisfactory performance. Convenient means for cleaning should be made available. Heat exchangers may be cleaned by either chemical or mechanical methods. The method selected must be the choice of the operator of the plant and will depend on the type of deposit and the facilities available in the plant. Following are several cleaning procedures that may be considered:</p> <ol style="list-style-type: none"> (1) Circulating hot wash oil or light distillate through tubes or shell at high velocity may effectively remove sludge or similar soft deposits. (2) Some salt deposits may be washed out by circulating hot fresh water. (3) Commercial cleaning compounds are available for removing sludge or scale provided hot wash oil or water is not available or does not give satisfactory results. (4) High pressure water jet cleaning. (5) Scrapers, rotating wire brushes, and other mechanical means for removing hard scale, coke, or other deposits. (6) Employ services of a qualified organization that provides cleaning services. These organizations will check the nature of the deposits to be removed, furnish proper solvents and/or acid solutions containing inhibitors, and provide equipment and personnel for a complete cleaning job.

APPENDIX-4

<p>E-4.32 CLEANING PRECAUTIONS</p>	<p>(1) Tubes should not be cleaned by blowing through individual tubes since this heats the tube and may result in severe expansion strain, deformation of the tube, or loosening of the tube-to-tubesheet joint. (2) When mechanically cleaning a tube bundle, care should be exercised to avoid damaging the tubes. (3) Cleaning compounds must be compatible with the metallurgy of the exchanger.</p>
<p>E-4.4 TUBE EXPANDING</p>	<p>A suitable tube expander should be used to tighten a leaking tube joint. Care should be taken to ensure that tubes are not over expanded.</p>
<p>E-4.5 GASKET REPLACEMENT</p>	<p>Gaskets and gasket surfaces should be thoroughly cleaned and should be free of scratches and other defects. Gaskets should be properly positioned before attempting to retighten bolts. It is recommended that when a heat exchanger is dismantled for any cause, it be reassembled with new gaskets. This will tend to prevent future leaks and/or damage to the gasket seating surfaces of the heat exchanger. Composition gaskets become dried out and brittle so that they do not always provide an effective seal when reused. Metal or metal jacketed gaskets, when compressed initially, flow to match their contact surfaces. In so doing they are work hardened and, if reused, may provide an imperfect seal or result in deformation and damage to the gasket contact surfaces of the exchanger.</p> <p>Bolted joints and flanges are designed for use with the particular type of gasket specified. Substitution of a gasket of different construction or improper dimensions may result in leakage and damage to gasket surfaces. Therefore, any gasket substitutions should be of compatible design. Any leakage at a gasketed joint should be rectified and not permitted to persist as it may result in damage to the gasket surfaces. Metal Jacketed type gaskets are widely used. When these are used with a tongue and groove joint without a nubbin, the gasket should be installed so that the tongue bears on the seamless side of the gasket jacket. When a nubbin is used, the nubbin should bear on the seamless side.</p>
<p>E-4.6 DIAPHRAGM INSTALLATION PROCEDURE</p>	<p>(1) Position diaphragm and tighten to remove all voids between diaphragm and component to which it will be welded. This may be accomplished by bolting the cover in place, by a series of clamps or any other means that guarantees that the diaphragm will not move during final bolt-up and crack the weld. (2) Make the diaphragm to component weld and liquid penetrant inspect. (3) Install cover and tighten studs to required torque or tension. (4) Liquid penetrant inspect weld again after tightening studs.</p>
<p>E-4.7 SPARE AND REPLACEMENT PARTS</p>	<p>The procurement of spare or replacement parts from the manufacturer will be facilitated if the correct name for the part, as shown in Section 1, Table N-2, of these Standards is given, together with the serial number, type, size, and other information from the name plate. Replacement parts should be purchased from the original manufacturer.</p>
<p>E-4.8 PLUGGING OF TUBES</p>	<p>In U-tube heat exchangers, and other exchanger of special design, it may not be feasible to remove and replace defective tubes. Defective tube may be plugged using commercially available tapered plugs with ferrules or tapered only plugs which may or may not be seal welded. Excessive tube plugging may result in reduced thermal performance, higher pressure drop, and/or mechanical damage. It is the user's responsibility to remove plugs and neutralize the bundle prior to sending it to a shop for repairs.</p>

- As per TEMA 2019 10th ED SECTION 4, Installation, Operation, and Maintenance -

APPENDIX-5

1. TIGHTENING TORQUE (for SA193-B7 / Metric Coarse)

Nut type	Hex. Nuts (ANSI B 18.2.4.2M)				Heavy Hex. Nuts (ANSI B 18.2.4.6M)			
	Joints without washers		Joints with washers		Joints without washers		Joints with washers	
	min.(Nm)	max.(Nm)	min.(Nm)	max.(Nm)	min.(Nm)	max.(Nm)	min.(Nm)	max.(Nm)
M8 x 1.25P	14	20	16	23	-	-	-	-
M10 x 1.50P	28	40	32	46	-	-	-	-
M12 x 1.75P	47	66	54	76	49	69	56	79
M16 x 2.00P	111	156	128	179	116	163	133	187
M20 x 2.50P	215	301	247	346	226	316	260	363
M22 x 2.50P	297	415	342	477	300	420	345	483
M24 x 3.00P	370	518	426	596	389	545	447	627
M27 x 3.00P	538	753	619	866	563	788	647	906
M30 x 3.00P	750	1049	863	1206	775	1085	891	1248
M36 x 3.00P	1317	1843	1515	2119	1364	1910	1569	2197
M42 x 3.00P	-	-	-	-	2194	3071	2523	3532
M48 x 3.00P	-	-	-	-	3304	4626	3800	5320
M56 x 3.00P	-	-	-	-	5209	7293	5990	8387
M64 x 3.00P	-	-	-	-	7729	10821	8888	12444
M72 x 3.00P	-	-	-	-	10950	15330	12593	17630

APPENDIX-5

2. TIGHTENING TORQUE (for SA193-B8-2 / Metric Coarse)

Nut type	Hex. Nuts (ANSI B 18.2.4.2M)				Heavy Hex. Nuts (ANSI B 18.2.4.6M)			
	Joints without washers		Joints with washers		Joints without washers		Joints with washers	
	min.(Nm)	max.(Nm)	min.(Nm)	max.(Nm)	min.(Nm)	max.(Nm)	min.(Nm)	max.(Nm)
M8 x 1.25P	14	19	16	22	-	-	-	-
M10 x 1.50P	27	38	31	44	-	-	-	-
M12 x 1.75P	45	63	52	72	47	65	54	75
M16 x 2.00P	106	148	122	170	111	155	128	178
M20 x 2.50P	164	229	189	263	172	240	198	276
M22 x 2.50P	225	315	259	362	228	319	262	367
M24 x 3.00P	281	393	323	452	295	413	339	475
M27 x 3.00P	334	467	384	537	350	489	403	562
M30 x 3.00P	466	652	536	750	481	674	553	775
M36 x 3.00P	627	877	721	1009	650	909	748	1045
M42 x 3.00P	-	-	-	-	-	-	-	-
M48 x 3.00P	-	-	-	-	-	-	-	-
M56 x 3.00P	-	-	-	-	-	-	-	-
M64 x 3.00P	-	-	-	-	-	-	-	-
M72 x 3.00P	-	-	-	-	-	-	-	-

APPENDIX-5

3. TIGHTENING TORQUE (for SA193-B8M-2 / Metric Coarse)

Nut type	Hex. Nuts (ANSI B 18.2.4.2M)				Heavy Hex. Nuts (ANSI B 18.2.4.6M)			
	Joints without washers		Joints with washers		Joints without washers		Joints with washers	
	min.(Nm)	max.(Nm)	min.(Nm)	max.(Nm)	min.(Nm)	max.(Nm)	min.(Nm)	max.(Nm)
M8 x 1.25P	13	18	15	18	-	-	-	-
M10 x 1.50P	26	36	30	41	-	-	-	-
M12 x 1.75P	43	60	49	69	44	62	56	79
M16 x 2.00P	101	141	116	162	105	147	133	187
M20 x 2.50P	164	229	189	263	172	240	260	363
M22 x 2.50P	225	315	259	362	228	319	345	483
M24 x 3.00P	281	393	323	452	295	413	447	627
M27 x 3.00P	334	467	384	537	350	489	647	906
M30 x 3.00P	466	652	536	750	481	674	891	1248
M36 x 3.00P	627	877	940	1316	650	909	1569	2197
M42 x 3.00P	-	-	-	-	-	-	-	-
M48 x 3.00P	-	-	-	-	-	-	-	-
M56 x 3.00P	-	-	-	-	-	-	-	-
M64 x 3.00P	-	-	-	-	-	-	-	-
M72 x 3.00P	-	-	-	-	-	-	-	-

APPENDIX-5

4. TIGHTENING TORQUE (for SA193-B7 / Unified Coarse)

Nut type	Hex. Nuts (ANSI B 18.2.2.2)				Heavy Hex. Nuts (ANSI B 18.2.2.2)			
	Joints without washers		Joints with washers		Joints without washers		Joints with washers	
	min.(Nm)	max.(Nm)	min.(Nm)	max.(Nm)	min.(Nm)	max.(Nm)	min.(Nm)	max.(Nm)
1/2 x 13UNC	54	76	62	87	57	80	66	92
5/8 x 11UNC	106	148	122	170	111	155	128	178
3/4 x 10UNC	185	259	213	298	192	269	221	309
7/8 x 9UNC	294	412	338	474	305	426	351	490
1 x 8UNC	438	613	504	705	452	632	520	727
1 1/8 x 8UNC	635	889	730	1022	653	914	751	1051
1 1/4 x 8UNC	883	1236	1015	1421	905	1267	1041	1457
1 3/8 x 8UNC	1185	1659	1363	1908	1213	1698	1395	1953
1 1/2 x 8UNC	1549	2168	1781	2493	1583	2215	1820	2547
1 5/8 x 8UNC	-	-	-	-	2024	2834	2328	3259
1 3/4 x 8UNC	-	-	-	-	2540	3556	2921	4089
1 7/8 x 8UNC	-	-	-	-	3132	4385	3602	5043
2 x 8UNC	-	-	-	-	3809	5333	4380	6133
2 1/4 x 8UNC	-	-	-	-	5456	7638	6274	8784
2 1/2 x 8UNC	-	-	-	-	7501	10501	8626	12076

APPENDIX-5

5. TIGHTENING TORQUE (for SA193-B8-2 / Unified Coarse)

Nut type	Hex. Nuts (ANSI B 18.2.2.2)				Heavy Hex. Nuts (ANSI B 18.2.2.2)			
	Joints without washers		Joints with washers		Joints without washers		Joints with washers	
	min.(Nm)	max.(Nm)	min.(Nm)	max.(Nm)	min.(Nm)	max.(Nm)	min.(Nm)	max.(Nm)
1/2 x 13UNC	52	72	60	83	55	76	63	87
5/8 x 11UNC	101	141	116	162	106	148	122	170
3/4 x 10UNC	176	247	202	284	183	256	210	294
7/8 x 9UNC	223	313	256	360	231	324	266	373
1 x 8UNC	333	465	383	535	343	480	394	552
1 1/8 x 8UNC	395	552	454	635	405	567	466	652
1 1/4 x 8UNC	548	767	630	882	562	787	646	905
1 3/8 x 8UNC	564	790	649	909	577	808	664	929
1 1/2 x 8UNC	737	1032	848	1187	753	1054	866	1212
1 5/8 x 8UNC	-	-	-	-	-	-	-	-
1 3/4 x 8UNC	-	-	-	-	-	-	-	-
1 7/8 x 8UNC	-	-	-	-	-	-	-	-
2 x 8UNC	-	-	-	-	-	-	-	-
2 1/4 x 8UNC	-	-	-	-	-	-	-	-
2 1/2 x 8UNC	-	-	-	-	-	-	-	-

APPENDIX-5

6. TIGHTENING TORQUE (for SA193-B8M-2 / Unified Coarse)

Nut type	Hex. Nuts (ANSI B 18.2.2.2)				Heavy Hex. Nuts (ANSI B 18.2.2.2)			
	Joints without washers		Joints with washers		Joints without washers		Joints with washers	
	min.(Nm)	max.(Nm)	min.(Nm)	max.(Nm)	min.(Nm)	max.(Nm)	min.(Nm)	max.(Nm)
1/2 x 13UNC	49	68	56	78	52	72	60	83
5/8 x 11UNC	96	134	110	154	100	140	115	161
3/4 x 10UNC	167	234	192	269	174	243	200	279
7/8 x 9UNC	223	313	256	360	231	324	266	373
1 x 8UNC	333	465	383	535	343	480	394	552
1 1/8 x 8UNC	395	552	454	635	405	567	466	652
1 1/4 x 8UNC	548	767	630	882	562	787	646	905
1 3/8 x 8UNC	564	790	649	909	577	808	664	929
1 1/2 x 8UNC	737	1032	917	1187	753	1054	866	1212
1 5/8 x 8UNC	-	-	-	-	-	-	-	-
1 3/4 x 8UNC	-	-	-	-	-	-	-	-
1 7/8 x 8UNC	-	-	-	-	-	-	-	-
2 x 8UNC	-	-	-	-	-	-	-	-
2 1/4 x 8UNC	-	-	-	-	-	-	-	-
2 1/2 x 8UNC	-	-	-	-	-	-	-	-

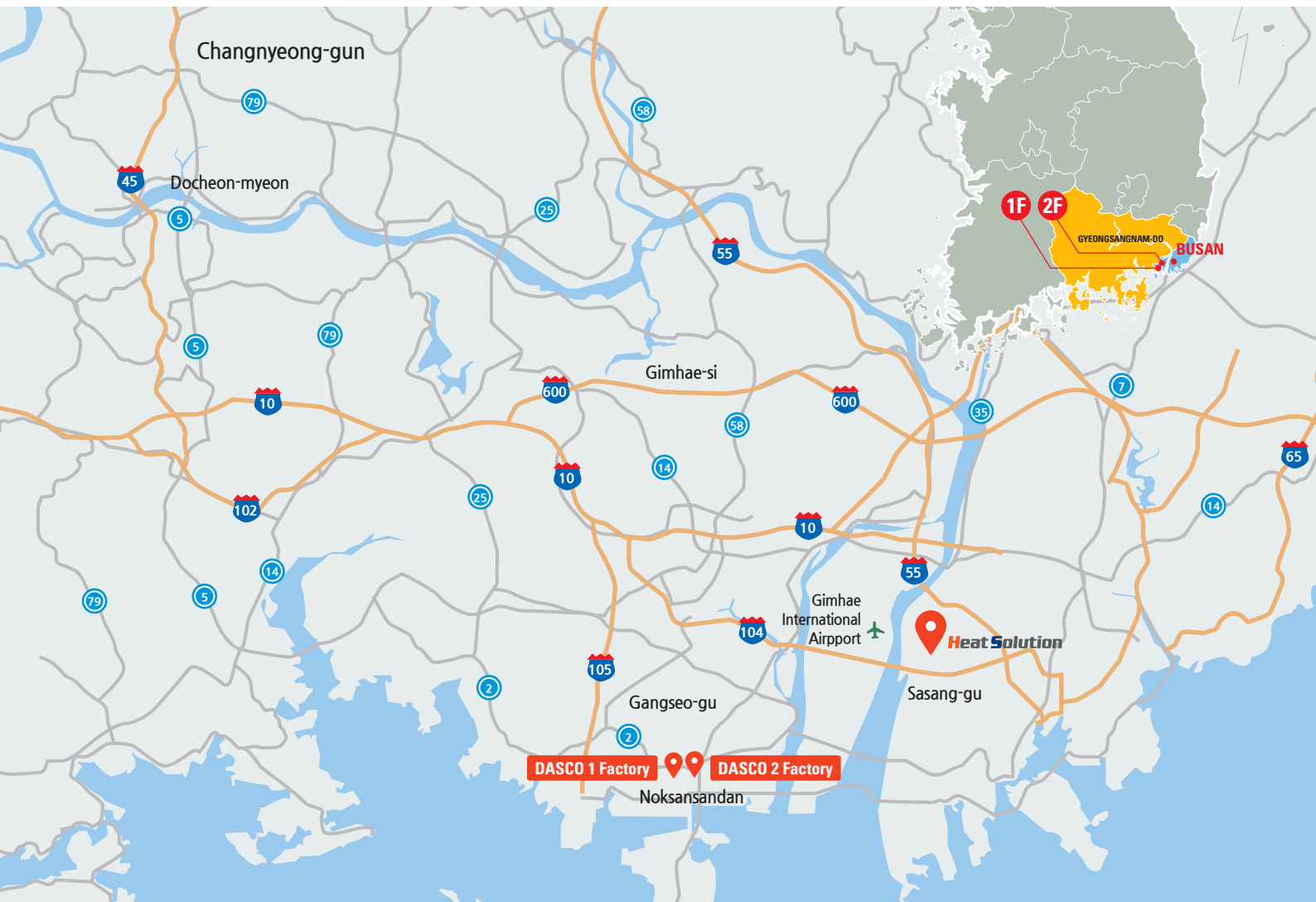

DYNAMIC & SPECIAL COMPANY

DASCO

DYNAMIC & SPECIAL COMPANY

DASCO

Head office and factory | 33, Noksansandan 17-ro 78beon-gil, Gangseo-gu, Busan, Korea
T. 82.51.973.4895 E-mail: dasco@dascohex.com <http://www.dascohex.com>

Factory 2 | 124, Noksansandan 27-ro, Gangseo-gu, Busan, Korea

for your good partner

Heat Solution

Hi Air Korea BLDG 1F, 10, Sasang-ro 181 beon-gil, Sasang-gu, Busan, Korea
T. 82.51.715.9981 E-mail: hs@heatsolution.co.kr